

1 HDF stackable valves

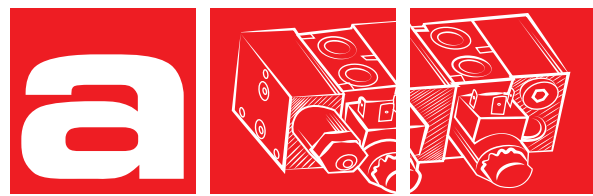

AMF DIRECT OPERATED PRESSURE REDUCING VALVE

AMF-RO-P/*

20 l/min - 32 MPa (320 bar)

1 DESCRIPTION

The module AMF-RO-P is designed to reduce the pressure in the P line. A 3 way cartridge valve with different pressure ranges is installed in a aluminium body suitable to be stacked with other HDF or AMF valves.

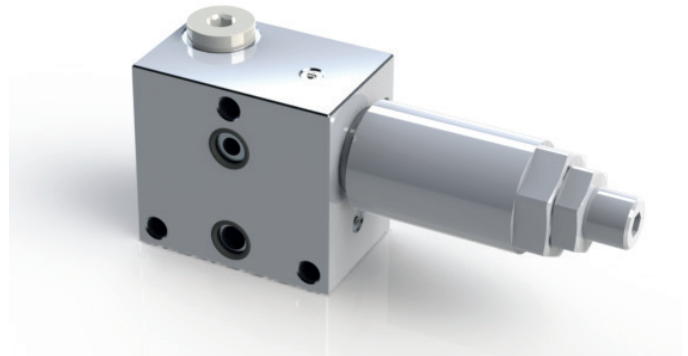

2 ORDERING CODE

(1)	(2)	(3)	(4)	(5)	(6)			
AMF	-	RO	-	P	/	-	/	10

(1) AMF: module stackable with 4 way solenoid valve HDF-ES

(2) RO: direct operated pressure reducing valve

(3) P: line where the control operates

(4) PR regulated pressure range:
 6,3: from 1,6 to 6,3 MPa (16 to 63 bar)
 16 : from 4,0 to 16,0 MPa (40 to 160 bar)
 20 : from 5,0 to 21,0 MPa (50 to 210 bar)

(5) Code reserved for option and variants

(6) Design number (progressive) of the valves

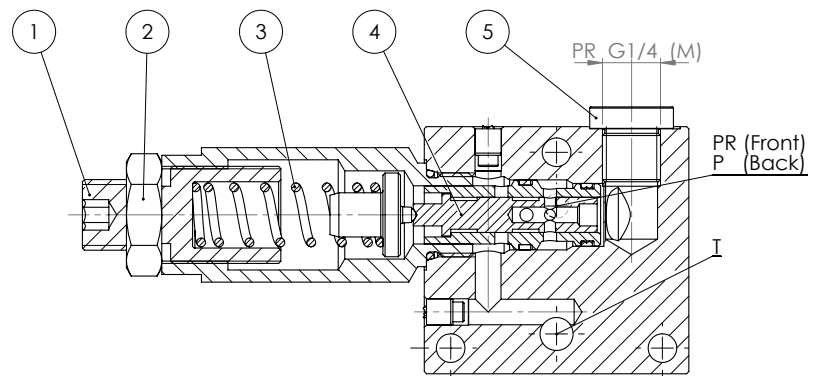
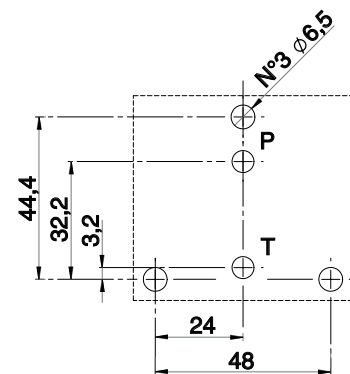

This 3-way direct operated pressure reducing valve is designed to maintain the desired value of pressure in the exit line(s) PR. Normally fluid flows from P to PR. The pressure in line PR acts on the control spool 4 (against the force due to spring 3), that shifts closing flow P to PR until the pressure falls back to the set value. If pressure in PR line overcomes the set value, the spool shifts until it opens the passage PR to T, allowing the oil to flow to the tank. Additional M (manometer) G 1/4" port is available (normally is closed by plug 5).

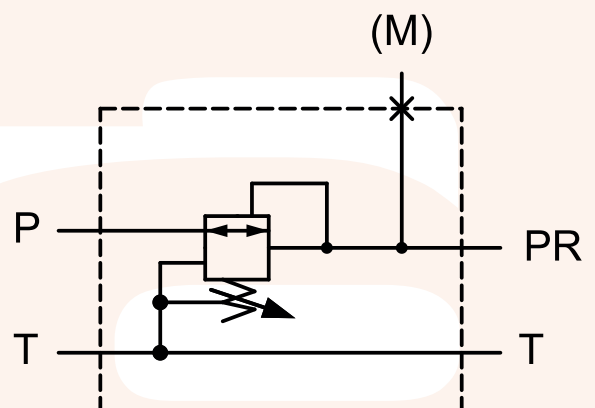

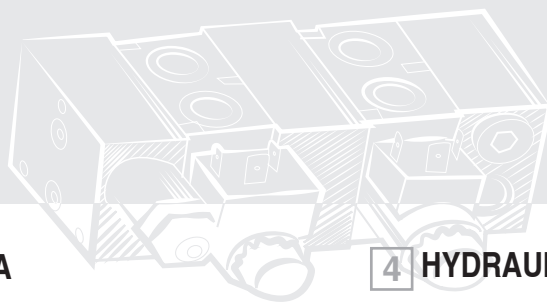

3 TECHNICAL DATA

Maximum nominal flow rate	20 l/min
Regulated pressure	see 2
Maximum input pressure (P line)	for 6,3 -> 16 MPa (160 bar) for 16 -> 25 MPa (250 bar) for 20 -> 32 MPa (320 bar)
Mass	0,65 Kg

4 HYDRAULIC FLUIDS

Seals and materials used on standard valves AMF are fully compatible with hydraulic fluids of mineral oil base, upgraded with antifoaming and antioxidantizing agents. The hydraulic fluid must be kept clean and filtered to ISO 4406 class 21/18/15, or better, and used in a recommended viscosity range from 10 cSt to 60 cSt.

5 INSTALLATION DIMENSIONS (mm)

Leakage between valve and mounting surface is prevented by the positive compression on their seats of 2 seals of OR type 2037 (9,25 x 1,78) or Quad-Rings (9,25 x 1,68 x 1,68 mm).

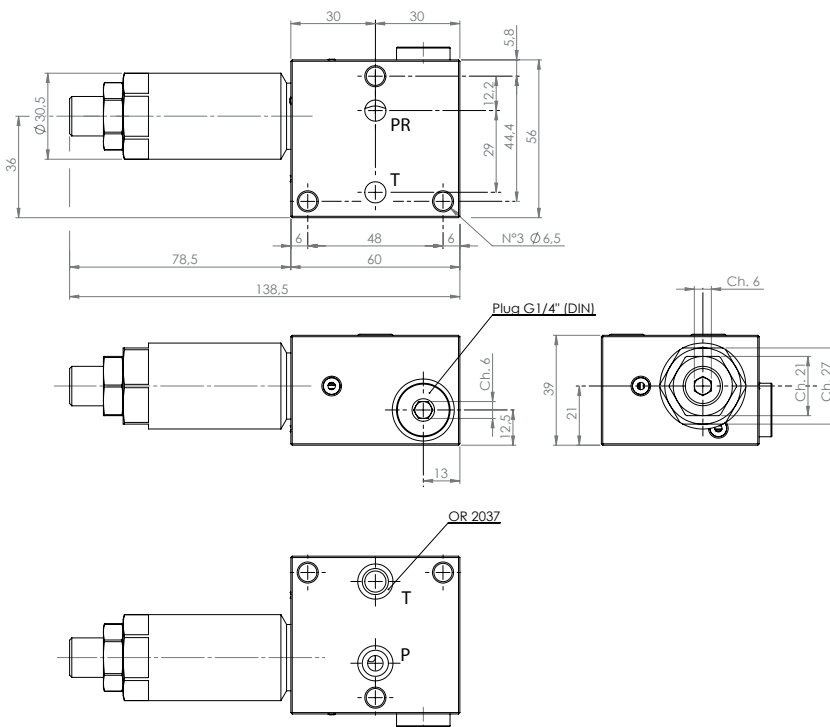

6 TYPICAL DIAGRAMS (measured at $v = 36$ cSt and 50°C)

