

2-WAY PRESSURE COMPENSATOR MODULAR VALVES

AM3-PC-*

32 l/min - 32 MPa (320 bar)

1 DESCRIPTION

2 Way pressure compensator for meter- in application. The pressure variations due to loading changes are compensated that means that an increase in pump pressure cannot result in any flow increase. Provided that there is no preloading of the outlet port, the use of a meter in pressure compensator is limited only to drives with exclusively positive load direction.

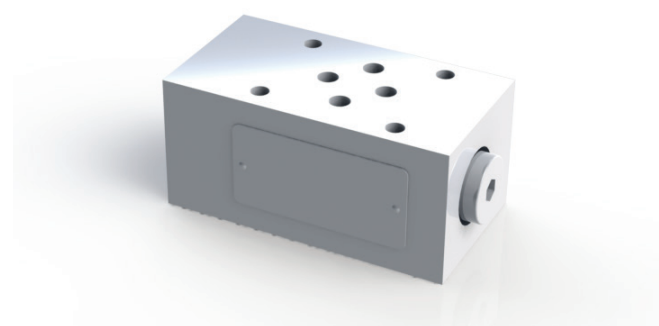

2 ORDERING CODE

(1)	(2)	(3)	(4)	(5)	(6)		
AM3	-	PC	-	/	-	/	10

(1) AM3: stackable valve CETOP 03 - Pressure 32 MPa (320 bar)

(2) PC: pressure compensator 2-way valve

(3) Service lines where the controls operate:

P: control on P with A, B selection

A: control on A

B: control on B

(4) Pressure compensator Δp

Δp standard= 1MPa (10 bar)

(5) Code reserved for more options and variants

(6) Design number (progressive) of the valves

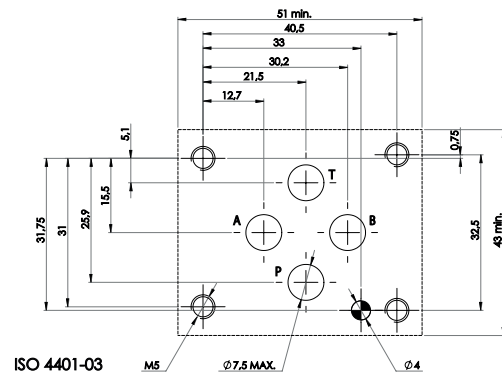

AM3-PC-P

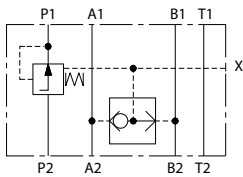

AM3-PC-A

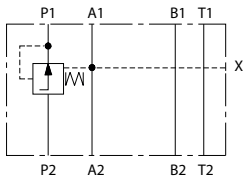

AM3-PC-B

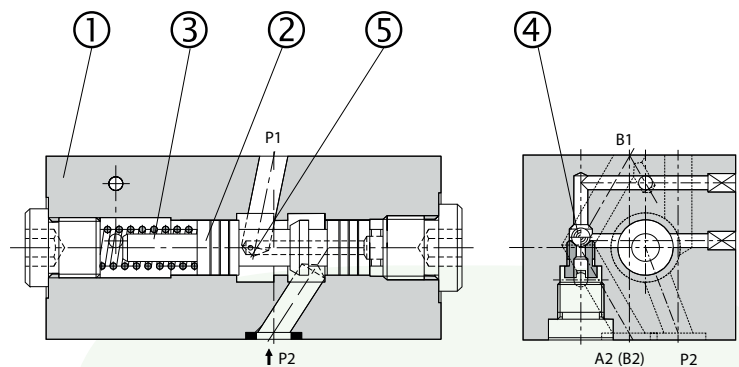
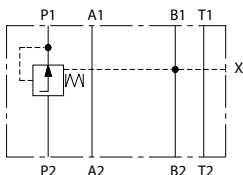

Valves AM3-PC-* are directly operated 2-way pressure compensators .

The main parts of these valves are the housing 1, control spool 2, spring 3 and logic valve 4. The spring 3 holds the spool in the open position from P2 to P1, provided that the pressure difference between P1 and A ($P1 - B$) is less than $p = 10$ bar. When the pressure difference exceeds the value of $p = 10$ bar, the spool shifts against spring until the desired pressure difference has been restored.

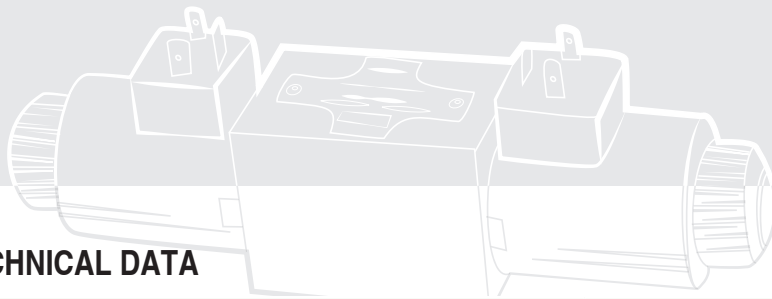

3 TECHNICAL DATA

Maximum rec. flow rate	32 l/min
Maximum nominal pressure	32 MPa (320 bar)
Pressure curves	see 4
Installation and dimensions	see 5
AM3-PC-P	approx 1,1 kg

4 TYPICAL DIAGRAMS

Typical curves for valves AM3-PC in standard configuration, with mineral oil at 36 cSt and at 50°C

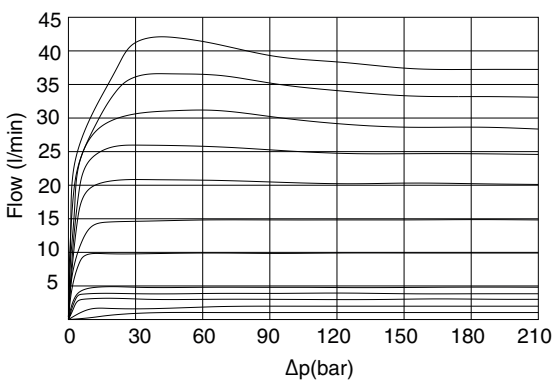

EXAMPLE

Two way pressure compensator for meter-in application

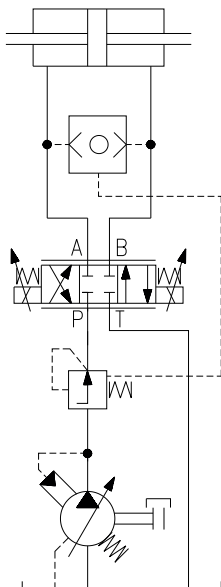

5 INSTALLATION DIMENSIONS (mm)

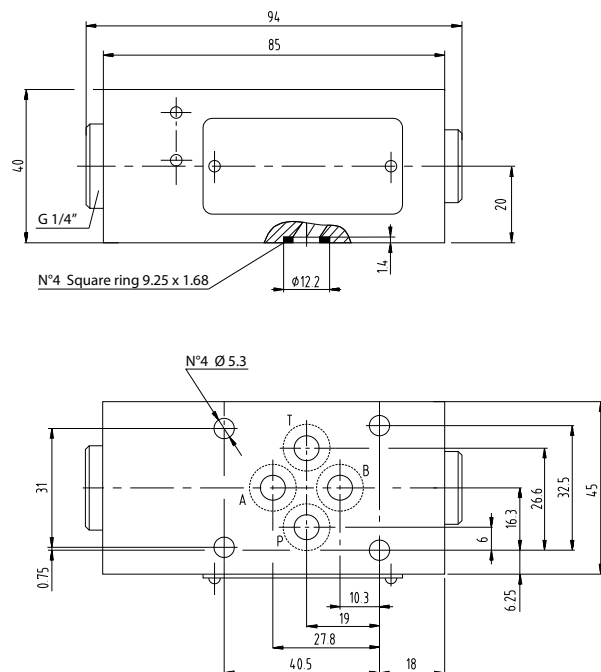

All stackable valves AM3-PC-* conform with ISO and CETOP specifications for mounting surface dimensions and for valves height 40 mm. Leakage between valve and mounting surface is prevented by the positive compression on their seats of 4 seals type OR 2037.

6 HYDRAULIC FLUIDS

Seals and materials used on standard valve AM3-* are fully compatible with hydraulic fluids of mineral oil base, upgraded with antifoaming and antioxidantizing agents. The hydraulic fluid must be kept clean and filtered to ISO 4406 class 19/17/14, or better, and used in a recommended viscosity range from 10 cSt to 60 cSt.